

Soil Moisture Testing Project

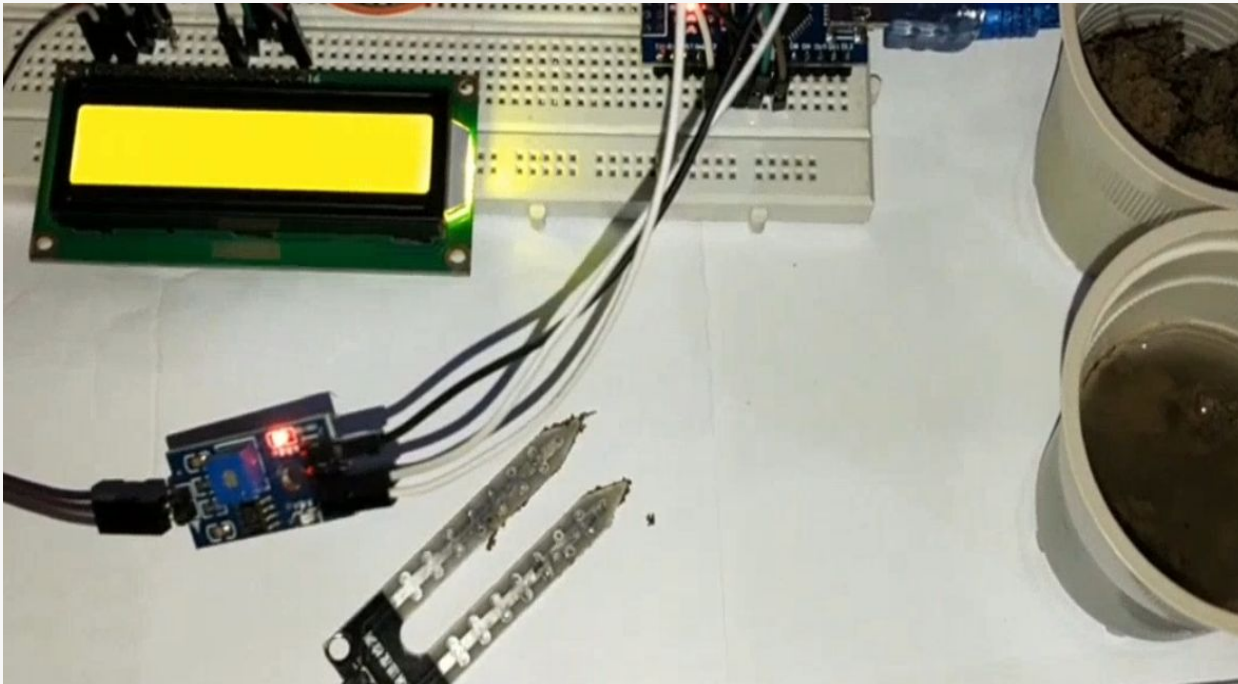

LCD (Liquid Crystal Display)

Liquid crystal displays (LCDs) are a commonly used to display data in devices such as calculators, microwave ovens, and many other electronic devices.

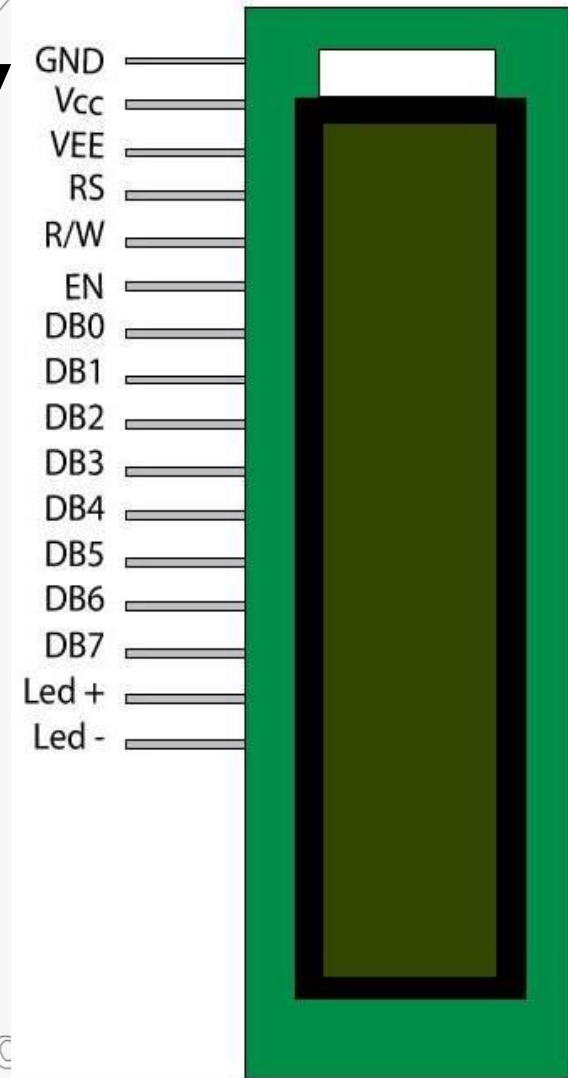
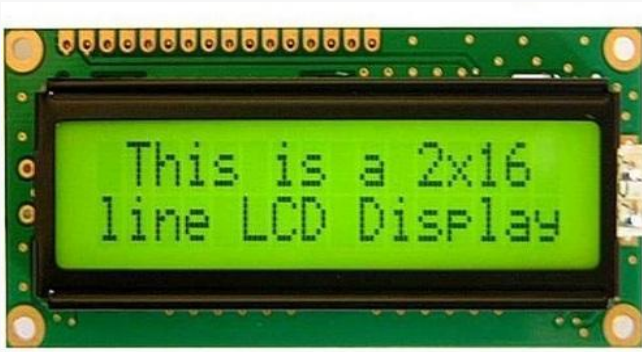

Soil Moisture Sensor

- The Soil Moisture Sensor measures soil moisture grace to the changes in electrical conductivity of the earth (soil resistance increases with drought).
- The electrical resistance is measured between the two electrodes of the sensor.
- A comparator activates a digital output when a adjustable threshold is exceeded.

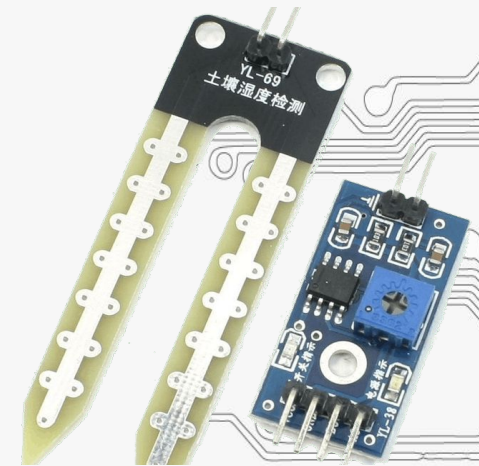

Working of Soil Moisture Sensor

- The soil moisture sensor consists of two probes that measure the volume of water in the soil. The two probes allow the electric current to pass through the soil and, according to its resistance, measures the moisture level of the soil.
- When there is more water, the soil conducts more electricity, which means that the resistance will be less. So the moisture level will be higher. Dry soil reduces conductivity. So, when there is less water, the soil conducts less electricity, which means it has more resistance. So the moisture level will be lower.

Working of project

- In this project, we have used the Soil Moisture Sensor.
- It has a detection length of 38mm and a working voltage of 2V-5V.
- It has a Fork-like design, which makes it easy to insert into the soil.
- The analog output voltage boosts along with the soil moisture level increases.
- Then the moisture level in percentage(%) will display on 16x2 LCD.

Components Required

- Arduino Nano
- 16x2 LCD
- Soil Moisture Sensor
- Potentiometer 10k
- Jumper wires
- Breadboard

Connection Diagram

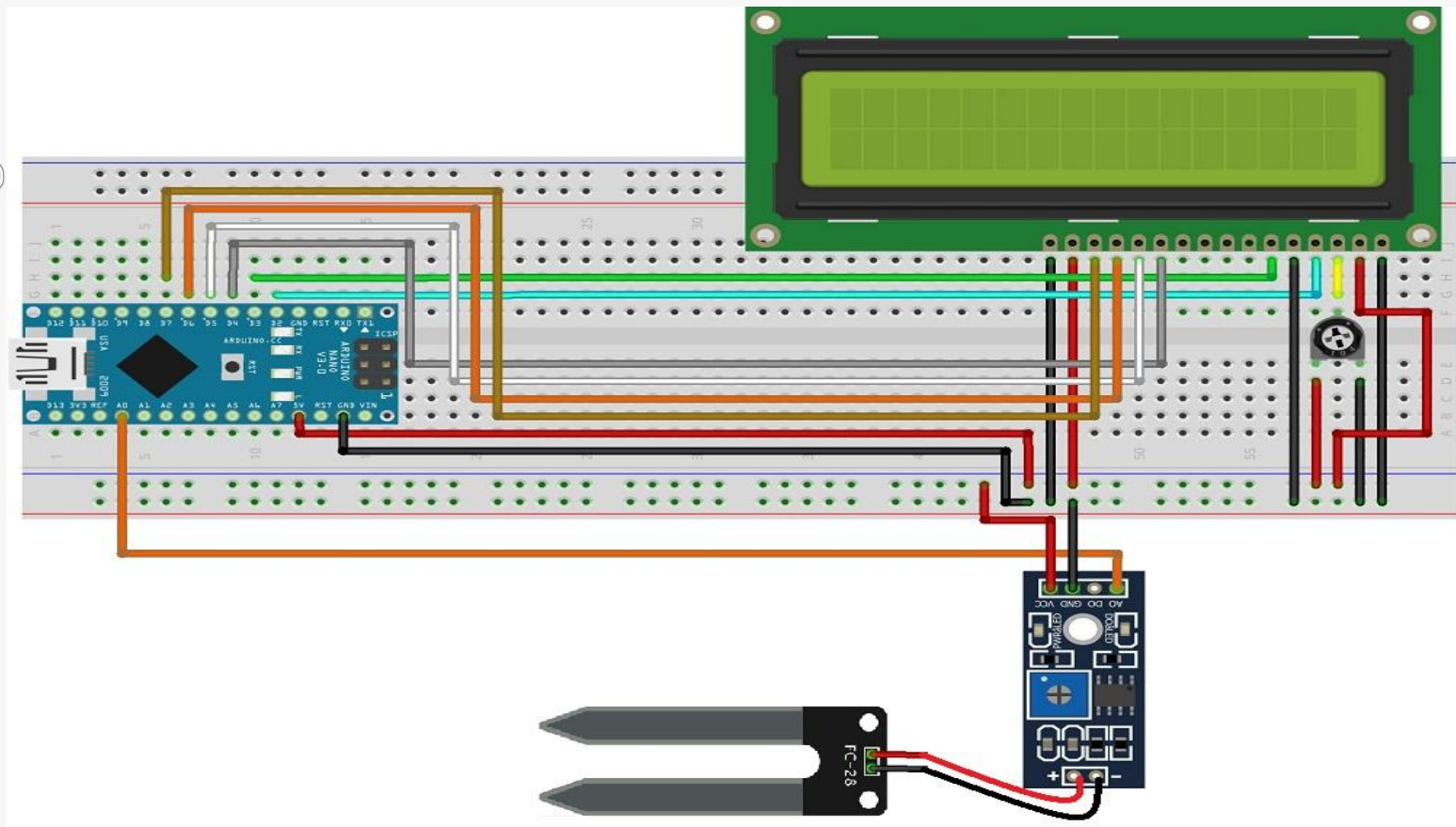

Connections for LCD :

- PIN1 or Vss to ground
- PIN2 or Vdd or Vcc to +5V power
- PIN3 or Vee to potentiometer (gives maximum contrast best for a beginner)
- PIN4 or RS (Register Selection) to D2 of Arduino
- PIN5 or RW (Read/Write) to ground
- PIN6 or E (Enable) to D3 of Arduino
- PIN11 or D4 to D4 of Arduino
- PIN12 or D5 to D5 of Arduino
- PIN13 or D6 to D6 of Arduino
- PIN14 or D7 to D7 of Arduino
- PIN15 or A to +5V of Arduino
- PIN16 or K to GND of Arduino

Connections for Soil Moisture Sensor

- Connect Ao pin of **Soil Moisture sensor** with Ao pin of Arduino Nano.
- Connect Vcc pin of **Soil Moisture sensor** with 5V pin of Arduino Nano.
- Connect GND pin of **Soil Moisture sensor** with GND pin of Arduino Nano.



ABLEEDUCATION™
ACTIVITY BASED LEARNING

Code

Soil_Moisture_testing_project | Arduino 1.8.19

File Edit Sketch Tools Help



Soil_Moisture_testing_project

```
#include <LiquidCrystal.h>
LiquidCrystal lcd(2,3,4,5,6,7);

int sensorPin = A0;
int sensorValue = 0;
int percentValue = 0;

void setup() {
  Serial.begin(9600);
  lcd.clear();
  lcd.begin(16, 2);
}

void loop() {

  sensorValue = analogRead(sensorPin);
  Serial.print("\n\nAnalog Value: ");
  Serial.print(sensorValue);

  percentValue = map(sensorValue, 1023, 200, 0, 100);
  Serial.print("\n\nPercentValue: ");
  Serial.print(percentValue);
  Serial.print("%");
  lcd.setCursor(0, 0);
```

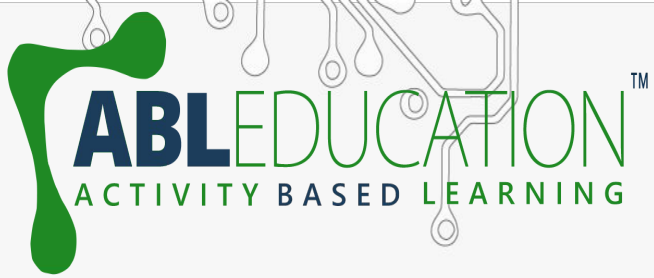

Soil_Moisture_testing_project | Arduino 1.8.19

File Edit Sketch Tools Help



Soil_Moisture_testing_project

```
lcd.clear();
lcd.begin(16, 2);
}

void loop() {

  sensorValue = analogRead(sensorPin);
  Serial.print("\n\nAnalog Value: ");
  Serial.print(sensorValue);

  percentValue = map(sensorValue, 1023, 200, 0, 100);
  Serial.print("\n\nPercentValue: ");
  Serial.print(percentValue);
  Serial.print("%");
  lcd.setCursor(0, 0);
  lcd.print("Soil Moisture");

  lcd.setCursor(0, 1);
  lcd.print("Percent: ");
  lcd.print(percentValue);
  lcd.print("%");
  delay(1000);
  lcd.clear();
}
```

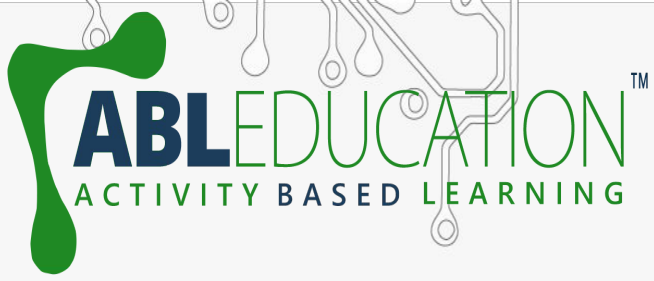

Project Link: <https://youtu.be/noqlh6zayvA>