

Interfacing of RFID Access module

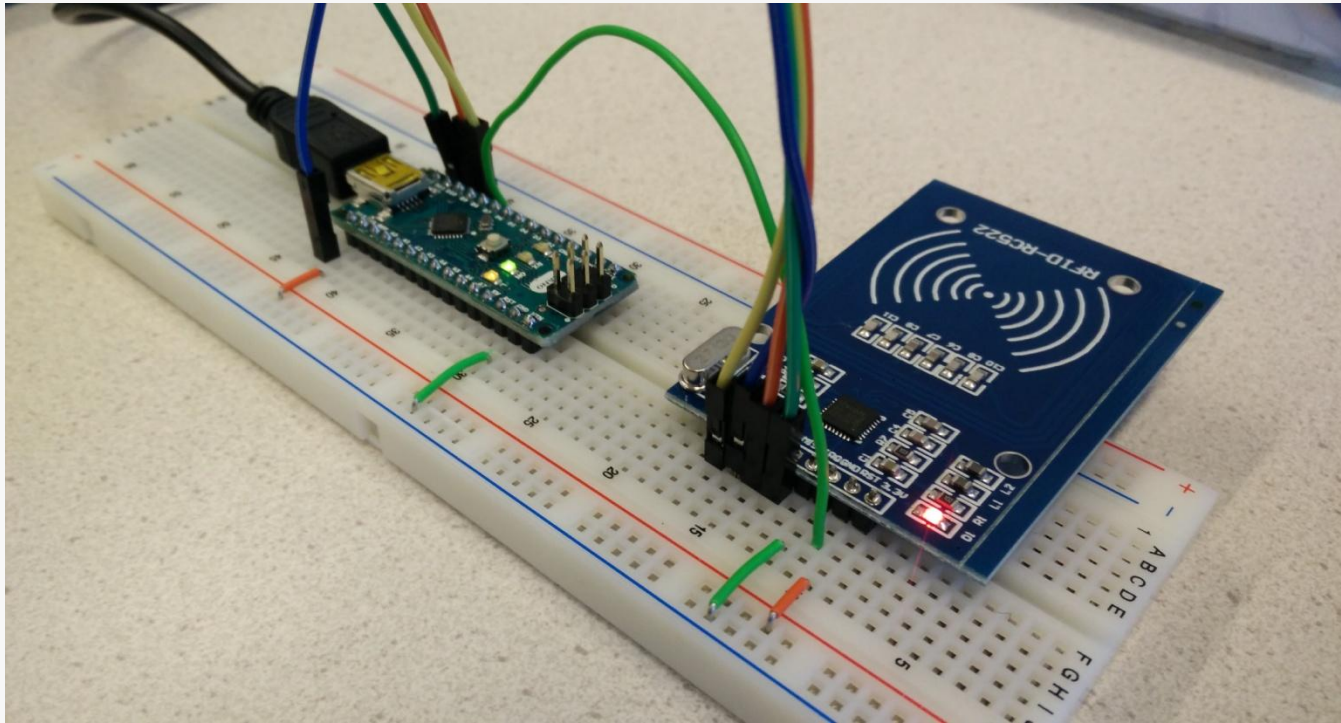

RFID

- Radio-frequency identification (**RFID**) is the wireless use of electromagnetic fields to transfer data, for the purposes of automatically identifying and tracking tags attached to objects. The tags contain electronically stored information.
- A radio frequency identification reader (**RFID reader**) is a device used to gather information from an RFID tag, which is used to track individual objects. Radio waves are used to transfer data from the tag to a reader.



Working of RFID Access module

- An RFID system consists of two main components, a transponder or a tag which is located on the object that we want to be identified, and a transceiver or a reader.
- Now as the tag is powered it can extract the transmitted message from the reader, and for sending message back to the reader, it uses a technique called load manipulation.
- Switching on and off a load at the antenna of the tag will affect the power consumption of the reader's antenna which can be measured as voltage drop.
- This changes in the voltage will be captured as ones and zeros and that's the way the data is transferred from the tag to the reader.

RFID with Arduino Nano

- Now let's see how we can use RFID with Arduino Nano. We will use tags that are based on the MIFARE protocol and the MFRC522 RFID reader.
- As for the RFID reader module, it uses the SPI protocol for communication with the Arduino board and here's how we need to connect them. Please note that we must connect the VCC of the module to 3.3V and as for the other pins we don't have to worry as they are 5V tolerant.
- Once we connect the module we need to download the MFRC522 library from GitHub.

- First we can upload the “DumpInfo” example and test whether our system works properly. Now if we run the Serial Monitor and bring the tag near the module, the reader will start reading the tag and all information from the tag will be displayed on the serial monitor.

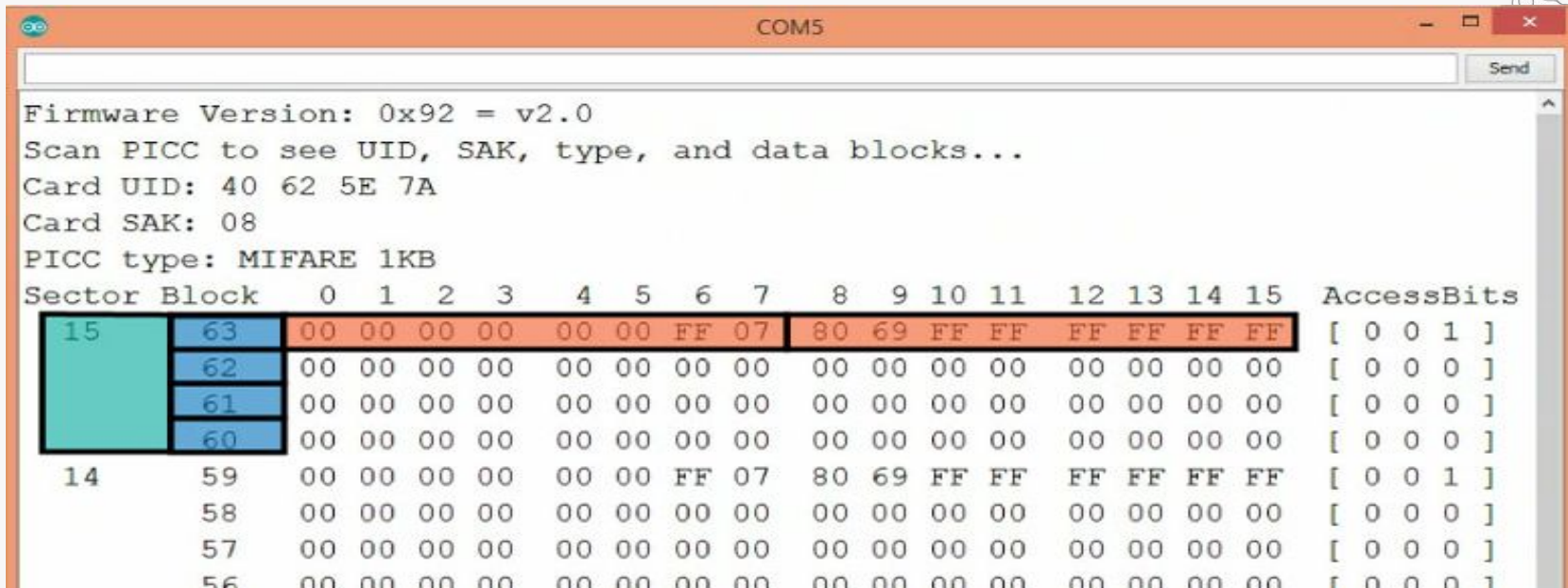

```

COM5
Firmware Version: 0x92 = v2.0
Scan PICC to see UID, SAK, type, and data blocks...
Card UID: 40 62 5E 7A
Card SAK: 08
PICC type: MIFARE 1KB
Sector Block  0  1  2  3  4  5  6  7  8  9 10 11 12 13 14 15  AccessBits
15  63  00 00 00 00  00 00 FF 07  80 69 FF FF  FF FF FF FF  [ 0 0 1 ]
    62  00 00 00 00  00 00 00 00  00 00 00 00  00 00 00 00  [ 0 0 0 ]
    61  00 00 00 00  00 00 00 00  00 00 00 00  00 00 00 00  [ 0 0 0 ]
    60  00 00 00 00  00 00 00 00  00 00 00 00  00 00 00 00  [ 0 0 0 ]
14  59  00 00 00 00  00 00 FF 07  80 69 FF FF  FF FF FF FF  [ 0 0 1 ]
    58  00 00 00 00  00 00 00 00  00 00 00 00  00 00 00 00  [ 0 0 0 ]
    57  00 00 00 00  00 00 00 00  00 00 00 00  00 00 00 00  [ 0 0 0 ]
    56  00 00 00 00  00 00 00 00  00 00 00 00  00 00 00 00  [ 0 0 0 ]
  
```

Components Required

- Arduino Nano
- RFID reader and tags
- Jumper Wires
- Breadboard

Connection Diagram

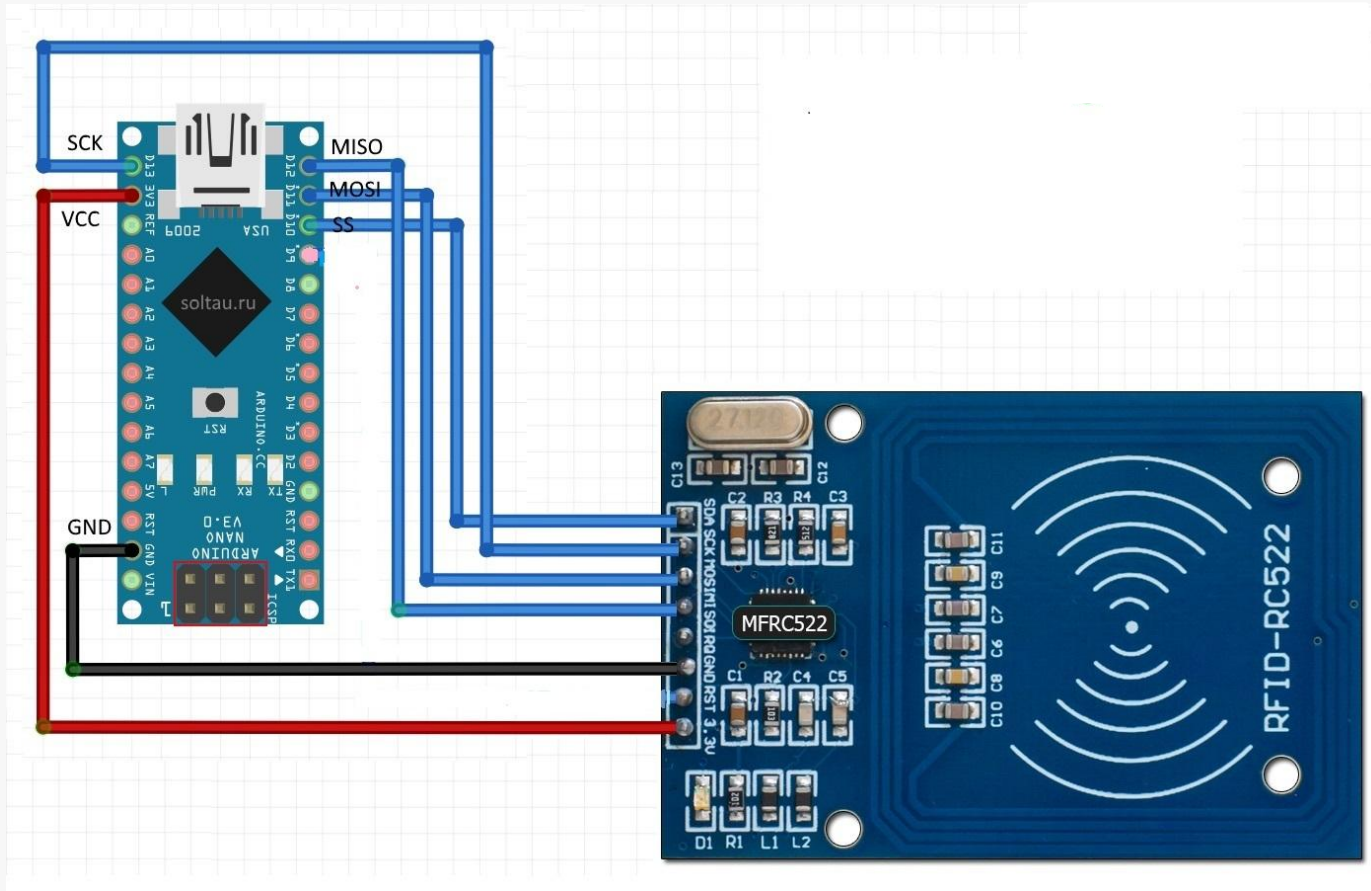

Connections

- Connect SDA pin of RFID reader with D10 pin of Arduino Nano.
- Connect SCK pin of RFID reader with D13 pin of Arduino Nano.
- Connect MOSI pin of RFID reader with D11 pin of Arduino Nano.
- Connect MISO pin of RFID reader with D12 pin of Arduino Nano.
- Connect GND pin of RFID reader with GND pin of Arduino Nano.
- Connect 3.3V pin of RFID reader with 3.3V pin of Arduino Nano.



Code

Interfacing_of_RFID_Access_module | Arduino 1.8.19

File Edit Sketch Tools Help



Interfacing_of_RFID_Access_module

```
#include <SPI.h>
#include <MFRC522.h>
#include <Servo.h>

#define SS_PIN 10
#define RST_PIN 9
MFRC522 mfrc522(SS_PIN, RST_PIN); // Create MFRC522 instance.

void setup()
{
  Serial.begin(9600); // Initiate a serial communication
  SPI.begin(); // Initiate SPI bus
  mfrc522.PCD_Init(); // Initiate MFRC522
  Serial.println("Put your card to the reader...");
  Serial.println();
}

void loop()
{
  // Look for new cards
  if ( ! mfrc522.PICC_IsNewCardPresent() )
  {
    return;
  }
  // Select one of the cards
  if ( ! mfrc522.PICC_ReadCardSerial() )
  {
```



Interfacing_of_RFID_Access_module

```
//Show UID on serial monitor
Serial.print("UID tag :");
String content= "";
byte letter;
for (byte i = 0; i < mfrc522.uid.size; i++)
{
    Serial.print(mfrc522.uid.uidByte[i] < 0x10 ? " 0" : " ");
    Serial.print(mfrc522.uid.uidByte[i], HEX);
    content.concat(String(mfrc522.uid.uidByte[i] < 0x10 ? " 0" : " "));
    content.concat(String(mfrc522.uid.uidByte[i], HEX));
}
Serial.println();
Serial.print("Message : ");
content.toUpperCase();
if (content.substring(1) == "07 23 AF 11") //change here the UID of the card/cards that you want to give access
{
    Serial.println("Authorized access");
    Serial.println();
    delay(500);
}
else {
    Serial.println(" Access denied");
    delay(1000);
}
}
```

Project Link : <https://youtu.be/Wc5YMF3s3yo>