

Interfacing of RGB LED

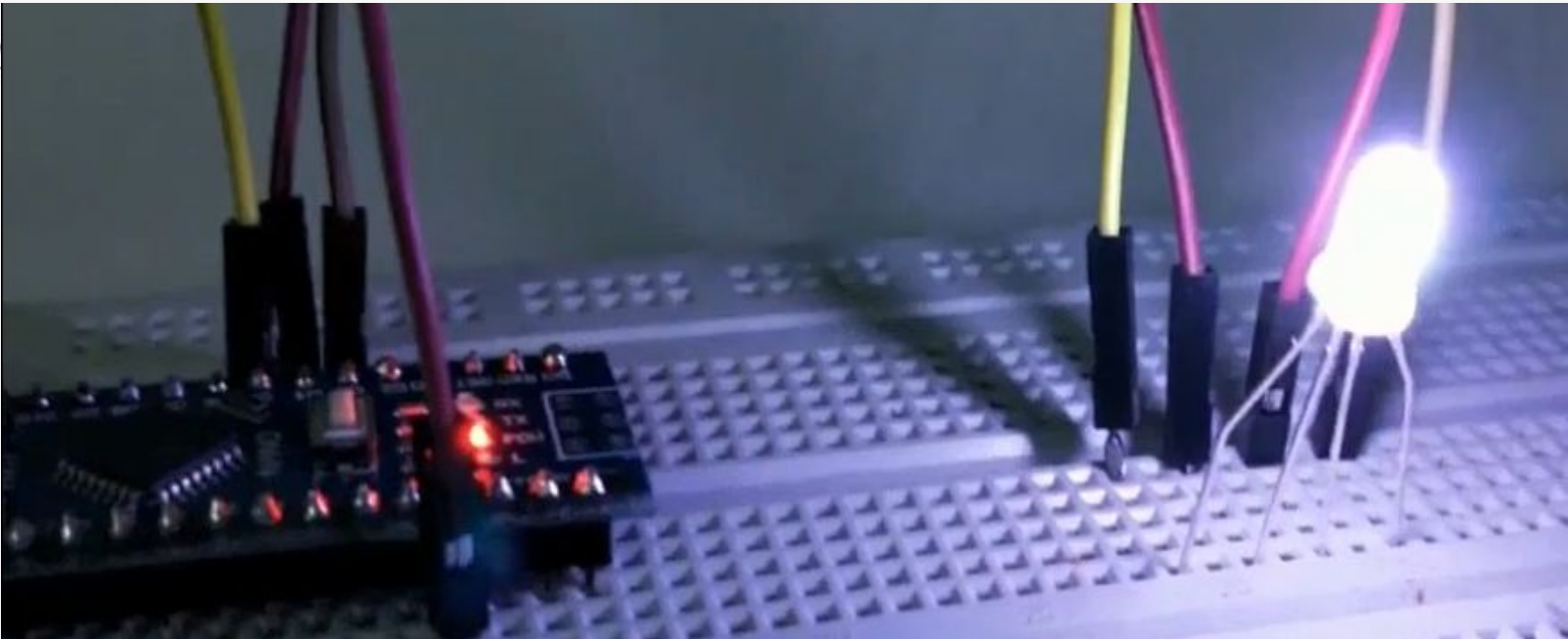

RGB LED

The RGB led consists of three different led's, from the name you can guess that these led's are red, green and blue. We can obtain many other colors by mixing up these colors. The Arduino has a analog write function which will help us in obtaining different colors for Arduino RGB led.

RGB LED Schematic

There are actually two types of RGB led's; the common cathode one and the common anode one. In the common cathode RGB led, the cathode of all the led's is common and we give PWM/digital signals to the anode of led's while in the common anode RGB led, the anode of all the led's is common and we give PWM/digital signals to the cathode of led's.

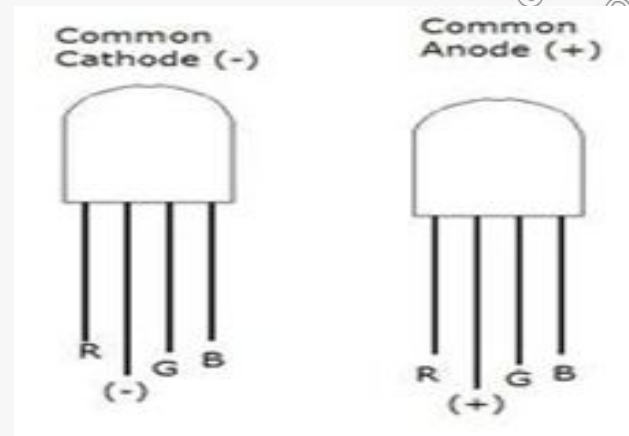
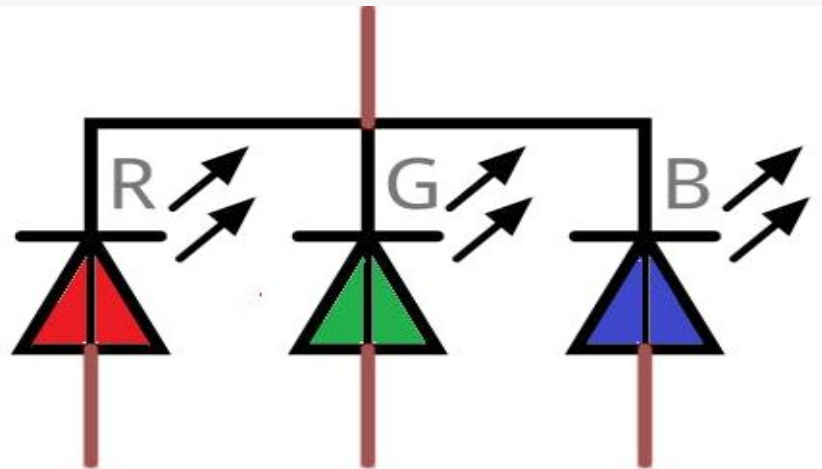

The one that we are going to use is the common anode RGB led. So, we will connect the common pin to the GND of Arduino and the other three leads of the led's to the digital pins of Arduino.

Note:-

You cannot distinguish between the common cathode and common anode type by just looking at the RGB led because both look same. You will have to make the connections to see that either it is common cathode or common anode.

The RGB led has one big lead than the other leads. In the common cathode case, it will be connected to GND and in the common anode case; it will be connected to 5V.

Working of RGB LED

- Inside the RGB led, there are three more led's. So by changing the brightness of these led's, we can obtain many other colors.
- To change brightness of RGB led, we can use the digital pins of Arduino.
- The digital pins will give signal different duty cycles to the RGB led to obtain different colors.

Components Required

- Arduino Nano
- RGB LED
- Breadboard
- Jumper Wires

Connection Diagram

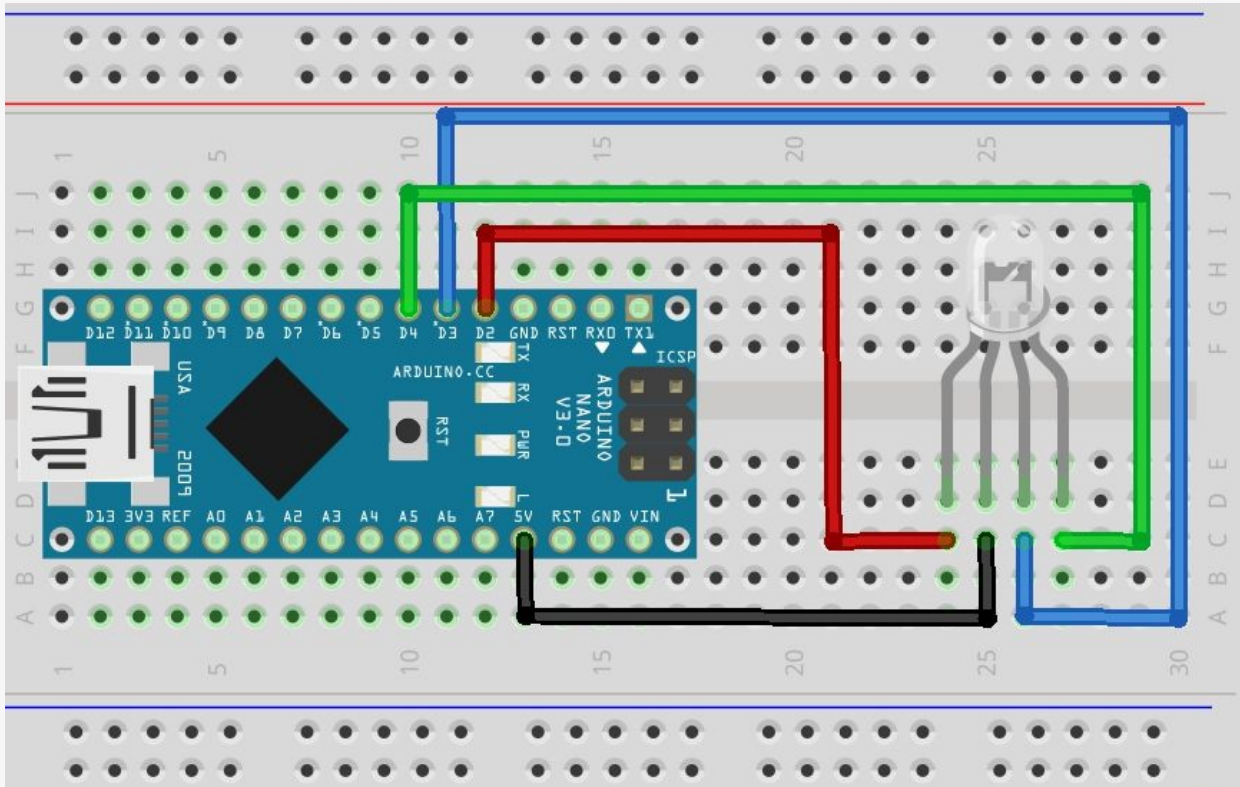

Connections

1. Connect the anode of the RGB led which is the longer pin of RGB led to the 5V of Arduino Nano.
2. The other three pins to the pin 2, 3, 4 of Arduino Nano.

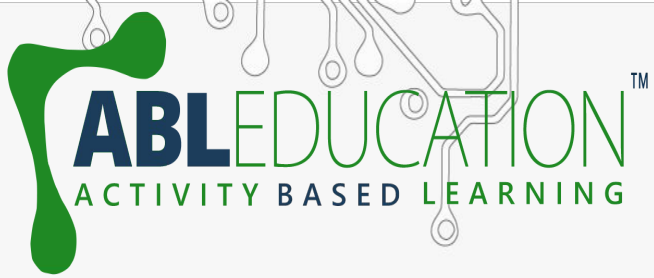

Code

Interfacing_of_RGB_LED | Arduino 1.8.19

File Edit Sketch Tools Help



Interfacing_of_RGB_LED

```
int redPin= 5;
int greenPin = 3;
int bluePin = 4;
void setup() {
  pinMode(redPin, OUTPUT);
  pinMode(greenPin, OUTPUT);
  pinMode(bluePin, OUTPUT);
}
void loop() {
  setColor(255, 255, 0); // Red Color
  delay(1000);
  setColor(0, 255, 0); // Green Color
  delay(1000);
  setColor(0, 255, 255); // Blue Color
  delay(1000);
  setColor(0, 0, 0); // White Color
  delay(1000);
  setColor(255, 0, 255); // Purple Color
  delay(1000);
}
void setColor(int redValue, int greenValue, int blueValue) {
  analogWrite(redPin, redValue);
  analogWrite(greenPin, greenValue);
  analogWrite(bluePin, blueValue);
}
```

Project Link: <https://youtu.be/NLc2lhMbFqs>