

Fire Alarm System

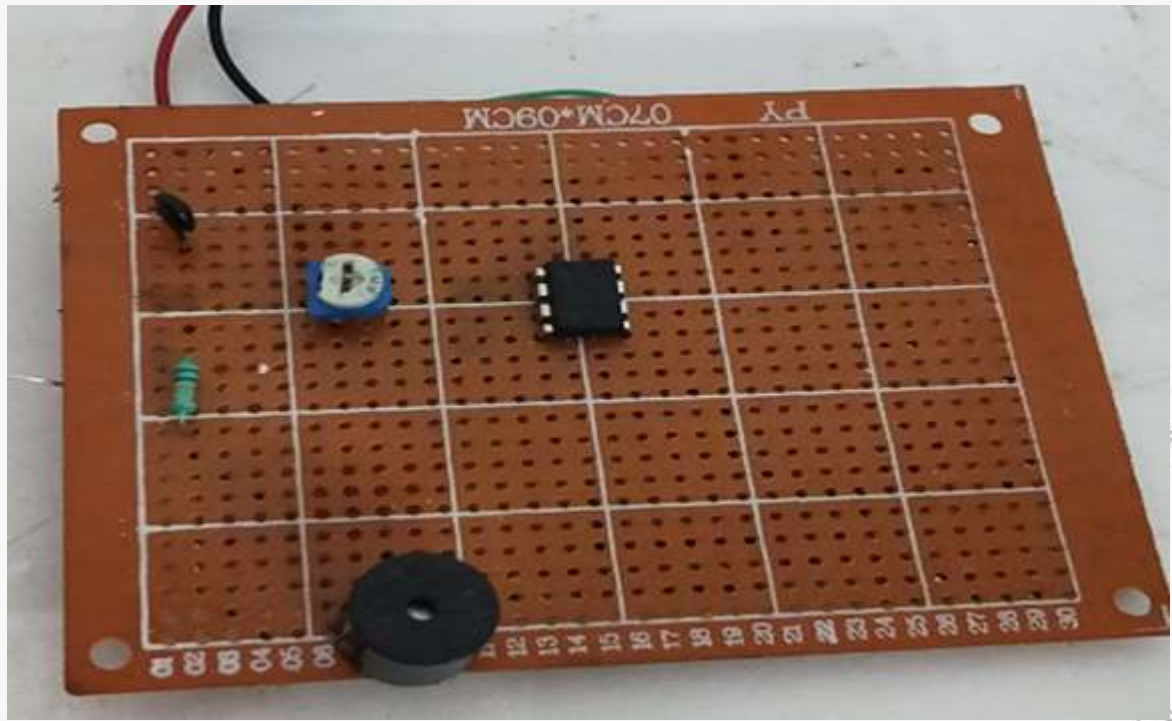

LM358 IC

- The LM358 IC is a great, low power and easy to use dual channel op-amp IC. It consists of two internally frequency compensated, high gain, independent op-amps.
- This IC is designed for specially to operate from a single power supply over a wide range of voltages. The LM358 IC is available in a chip sized package and applications of this op amp include conventional op-amp circuits, DC gain blocks and transducer amplifiers.
- LM358 IC is a good, standard operational amplifier and it is suitable for your needs. It can handle 3-32V DC supply & source up to 20mA per channel.

Thermistor

- A thermistor is a thermally sensitive resistor that exhibits a precise and predictable change in resistance proportional to small changes in body temperature.
- How much its resistance will change is depend upon its unique composition. Thermistors are part of a larger group of passive components.
- And unlike their active component counterparts, passive devices are incapable of providing power gain, or amplification to a circuit.

About Project

Fire Alarm Circuit is a simple circuit that detects the fire and activates the Siren Sound or Buzzer. Fire Alarm Circuits are very important devices to detect fire in the right time and prevent any damage to people or property.

Working of project

- In this project, first thing to know is that the main component in detecting the fire is the 10 K Thermistor. If the temperature increases, the resistance of the Thermistor decreases.
- In case of fire, the temperature increases. This increase in temperature will reduce the resistance of the 10 K Thermistor. As the resistance decreases, the output of the voltage divider will increase. Since the output of the voltage divider is given to the non – inverting input of the LM358 Op – Amp, its value will become more than that of the inverting input. As a result, the output of the Op – Amp becomes high and it activates the buzzer.

Components Required

- 10 K Thermistor
- LM358 Operational Amplifier (Op – Amp)
- 4.7 K Ω Resistor (1/4 Watt)
- 10 K Ω Potentiometer
- Small Buzzer (5V Buzzer)
- Soldering wire
- Soldering IRON
- Zero PCB
- Battery Connector
- 5V Power Supply

Connection Diagram

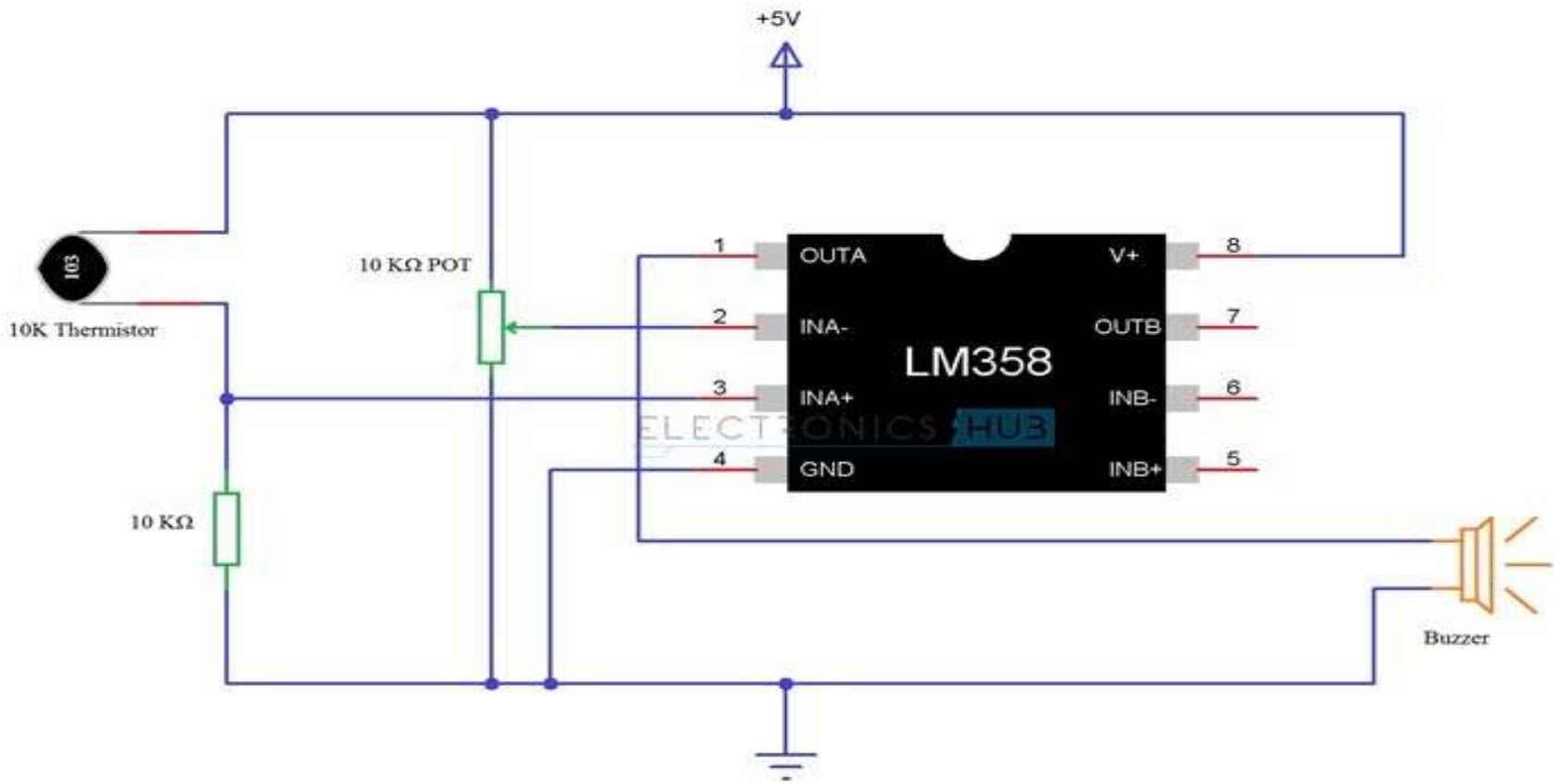

Future Scope

- Fire Alarm Circuits are very useful in homes, offices, schools, labs, etc. to detect and prevent any disasters due to fire.
- Fire Alarm Systems can work as a stand - alone devices or can be a part of a complex home security system with other security features like smoke detection, intruder alert, motion detection, etc.

Project Link : <https://youtu.be/R0XhJmFG7Lw>