

Police Siren using Timer IC 555

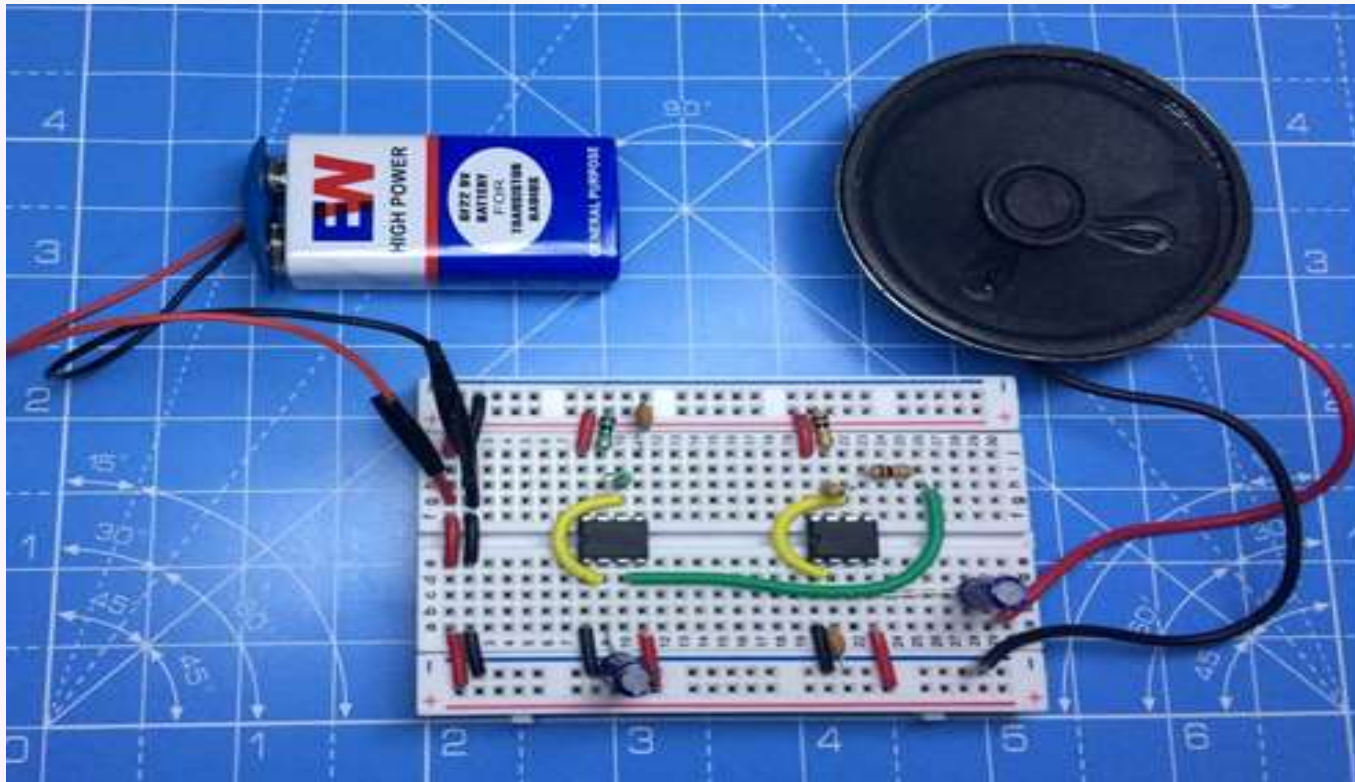

About project

The project of a police siren based on NE555 timer IC. The circuit uses two NE555 timers ICs and each of them are wired as Astable multivibrators. The circuit can be powered from anything between 6 to 15V DC. By connecting an additional power amplifier at the output you can further increase the loudness.

Timer IC 555

- Here is a pulse/frequency generator using the popular timer IC 555 which is wired as an Astable Multivibrator. The output pulses can be indicated visually by the LED. This circuit does not require any external trigger to change the state of the output, hence the name free-running. This circuit can be used in applications that require clock pulses.
- An Astable Multivibrator can be produced by adding resistors and a capacitor to the basic timer IC 555. The timing during which the output is either high or low is determined by the externally connected two resistors (R_1 & R_2) and a capacitor (C_1).

Pin Diagram

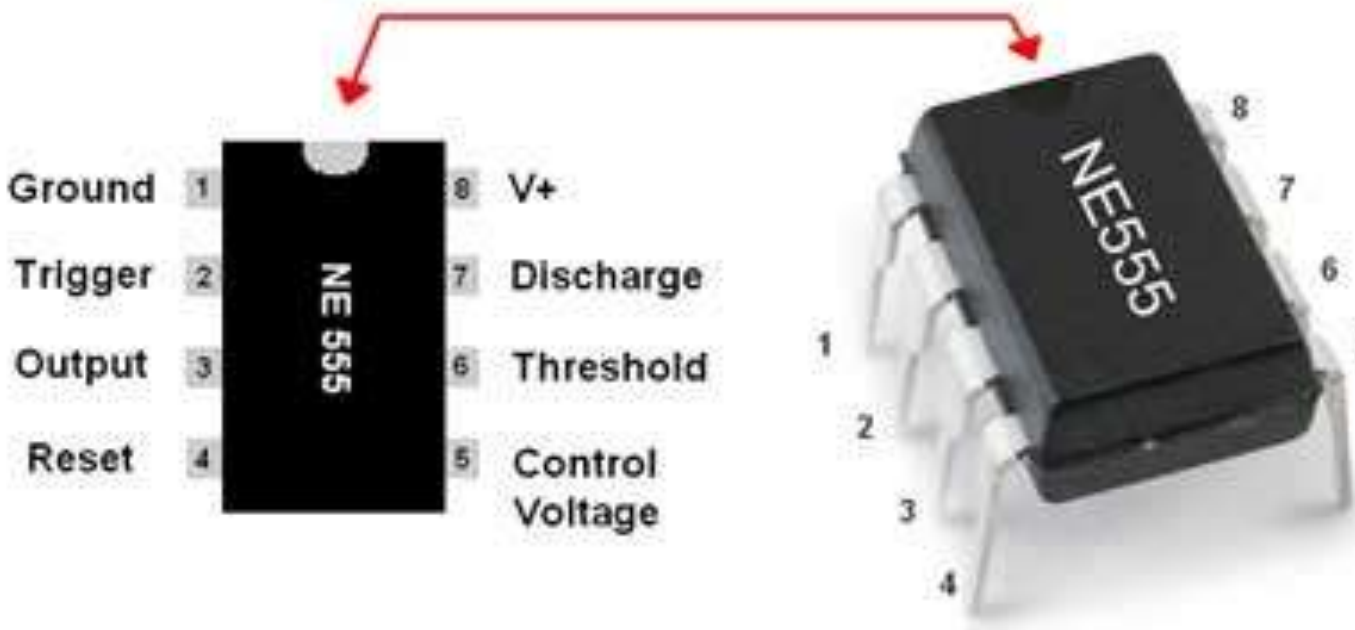

1N4007 Diode

- **1N4007** is a PN junction rectifier **diode**. These types of **diodes** allow only the flow of electrical current in one direction only. So, it can be **used** for the conversion of AC power to DC.
- This diode is designed specifically for circuits that needs to convert alternating current into direct current. It can pass currents of up to 1 A, and have peak inverse voltage (PIV) rating of 1,000 V.



Working of project

- IC1 is wired as a slow Astable multivibrator operating at around 20Hz @ 50% duty cycle and IC2 is wired as fast Astable multivibrator operating at around 600Hz.
- The output of first Astable mutivibrator is connected to the control voltage input (pin5) of IC2. This makes the output of IC2 modulated by the output frequency of IC1, giving a siren effect.
- In simple words, the output frequency of IC2 is controlled by the output of IC1.

Components Required

- Two 555 Timer IC
- One 8 Ohm Speaker
- IN4007 Diode
- Two 68k and three 10k Resistors
- One 100uF, One 10uF, One 104nF and One 103nF Capacitors
- Breadboard
- One +9 Volt Battery
- One Battery Cap
- Connecting Wires

Connection Diagram

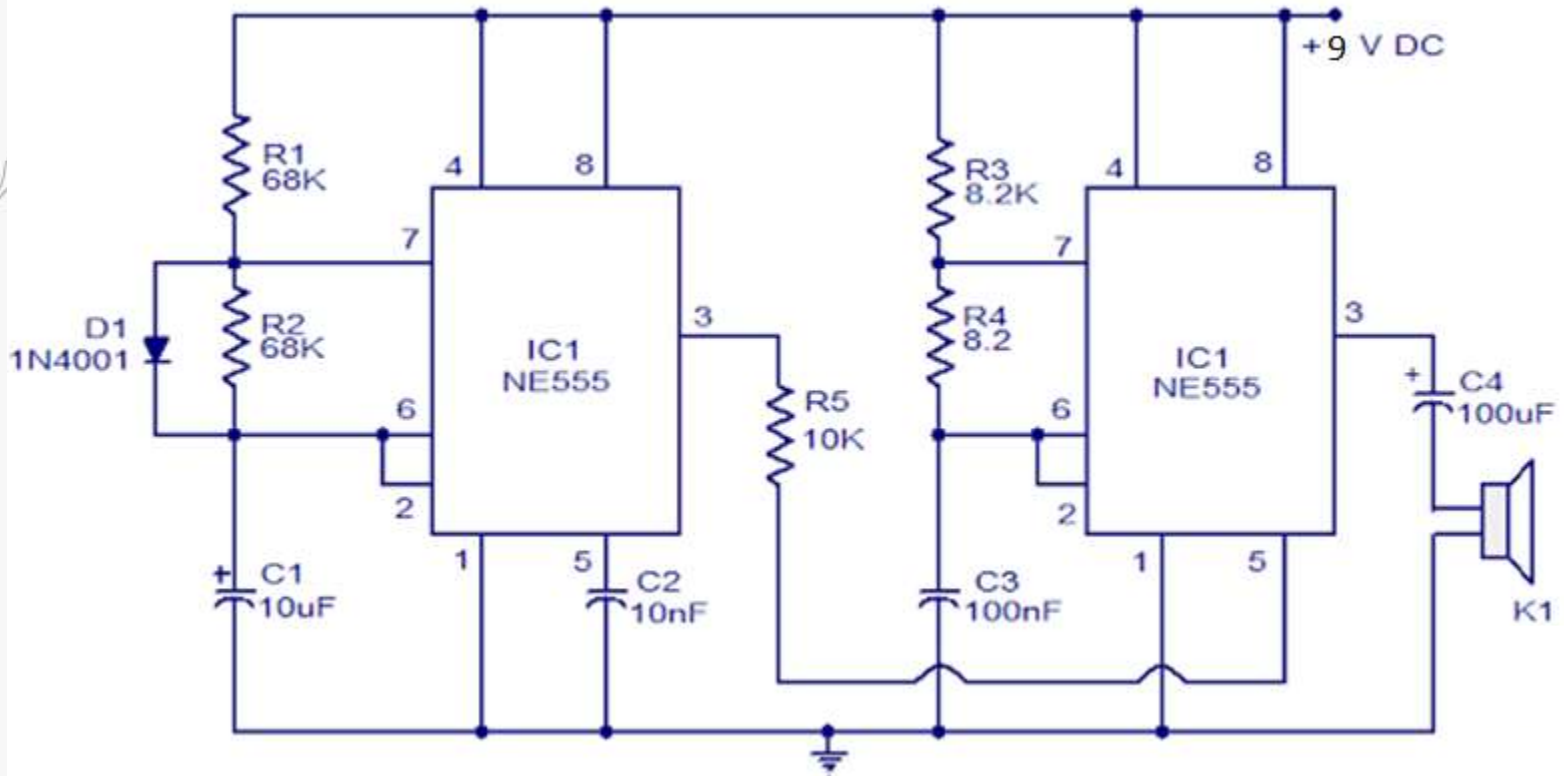



Project Link : <https://youtu.be/ahCe5yUQR48>