

Controlling LED using Switch

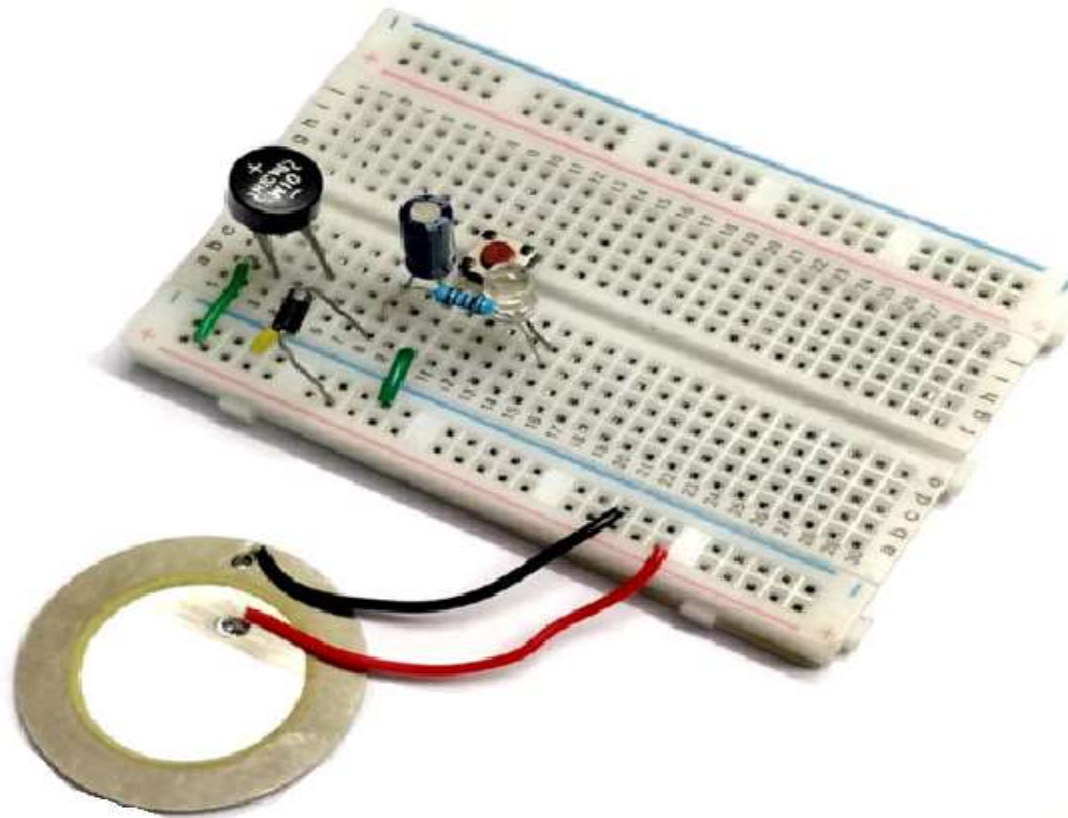

About project

This project is developed by using 555 timer IC operated as a MONOSTABLE vibrator. Here the stable stage is LOW, so the timer outputs low after the trigger is removed. Basically in this circuit we will have a LED which turns ON when we touch a pin of timer. The LED will be ON for the time during which the trigger is present. Once the trigger is removed the LED turns OFF.

Piezoelectric Plate

A **piezoelectric plate** is a device that uses the **piezoelectric** effect to measure pressure, acceleration, strain or force by converting them to an electrical charge. The most common **piezoelectric** material is quartz. Certain ceramics, Rochelle salts, and various other solids also exhibit this effect.

Timer IC 555

- Here is a pulse/frequency generator using the popular timer IC 555 which is wired as an Astable Multivibrator. The output pulses can be indicated visually by the LED. This circuit does not require any external trigger to change the state of the output, hence the name free-running. This circuit can be used in applications that require clock pulses.
- An Astable Multivibrator can be produced by adding resistors and a capacitor to the basic timer IC 555. The timing during which the output is either high or low is determined by the externally connected two resistors (R_1 & R_2) and a capacitor (C_1).

Pin Diagram

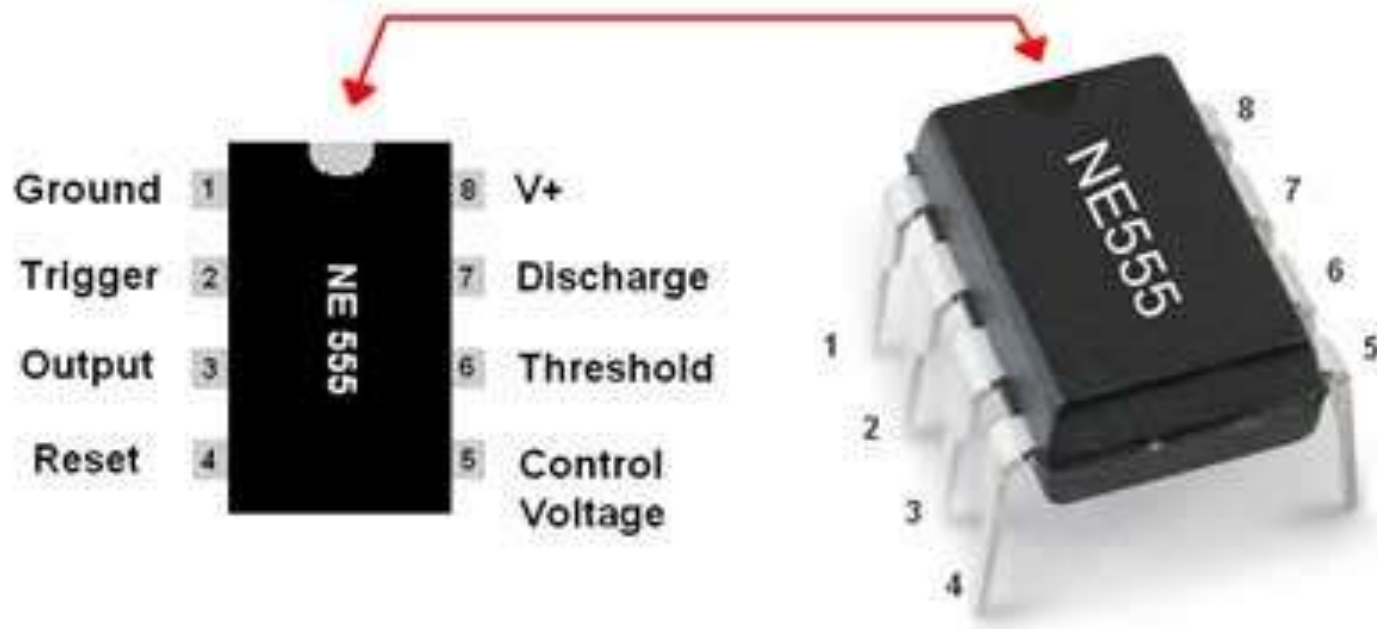

Working of project

- The capacitor between pin6 and pin1 determines the turn on time of LED once a trigger is passed. This circuit can be modified to turn ON for Two minutes for a single trigger by replacing the 10uF capacitance with a 1000uF one. So with the capacitance change one can get many turn on times and so can make the use of this circuit as a stair case lamp.
- The touch switch circuit is connected on the breadboard as per the circuit diagram, and power is turned ON. Now the LED will not turn on as the trigger is not given.
- This pin can be pulled high by human body potential. This trigger determines the output of 555. When this pin is high the output will be high and when this pin is low the output is low. So once the trigger is given the turn on time of the LED depends on the charging time of the capacitor.

Components Required

- One 555 Timer IC
- One Touch Plate
- One 100k and One 470 Ohm Resistors
- One 10 μ F Capacitor
- One 104nF Ceramic Capacitor
- One LED
- One Breadboard
- One +9 Volt Battery
- One Battery Cap
- Connecting Wires

Connection Diagram

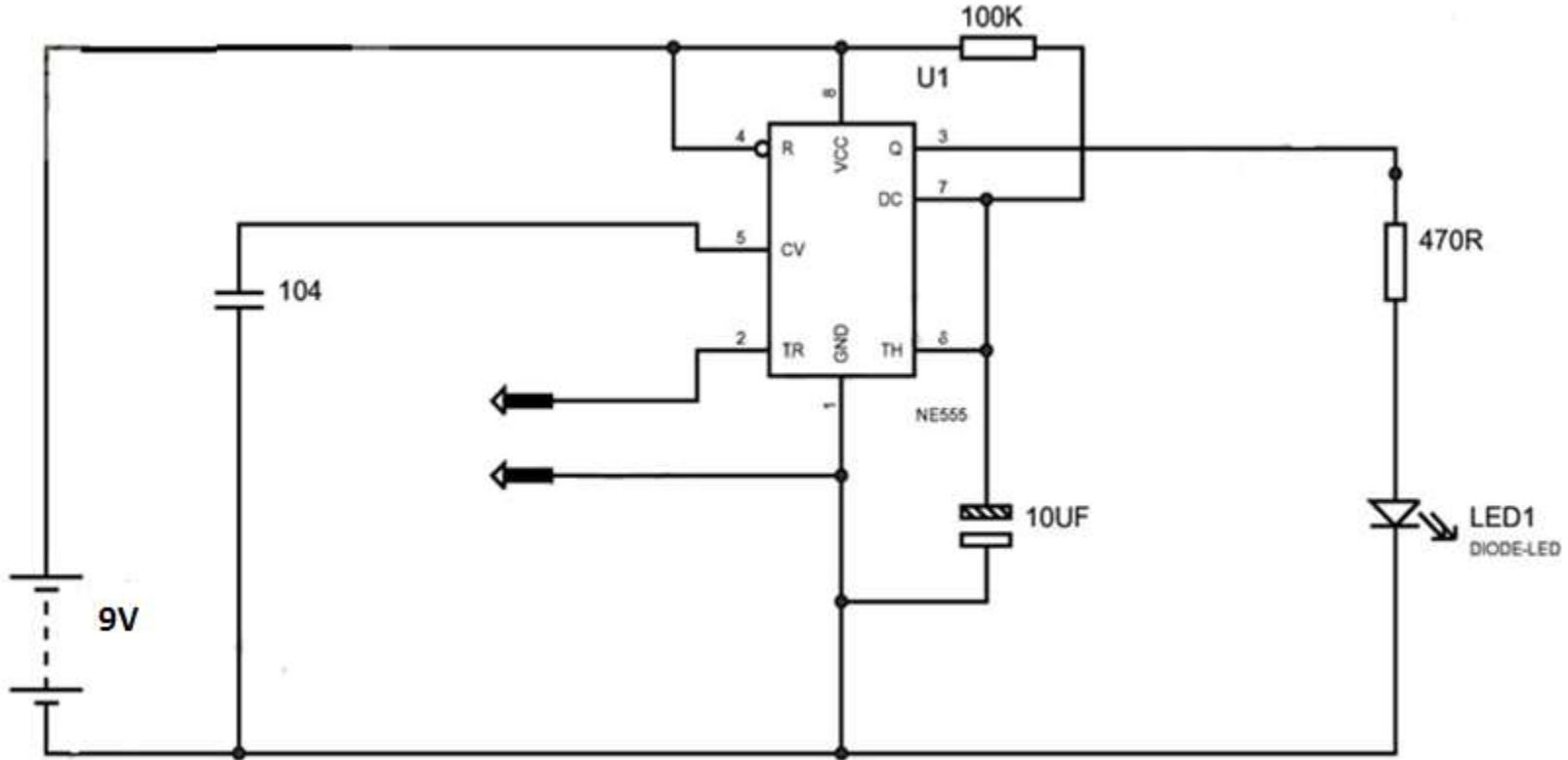

Project Link : <https://youtu.be/Gp-VbPoGvw8>